

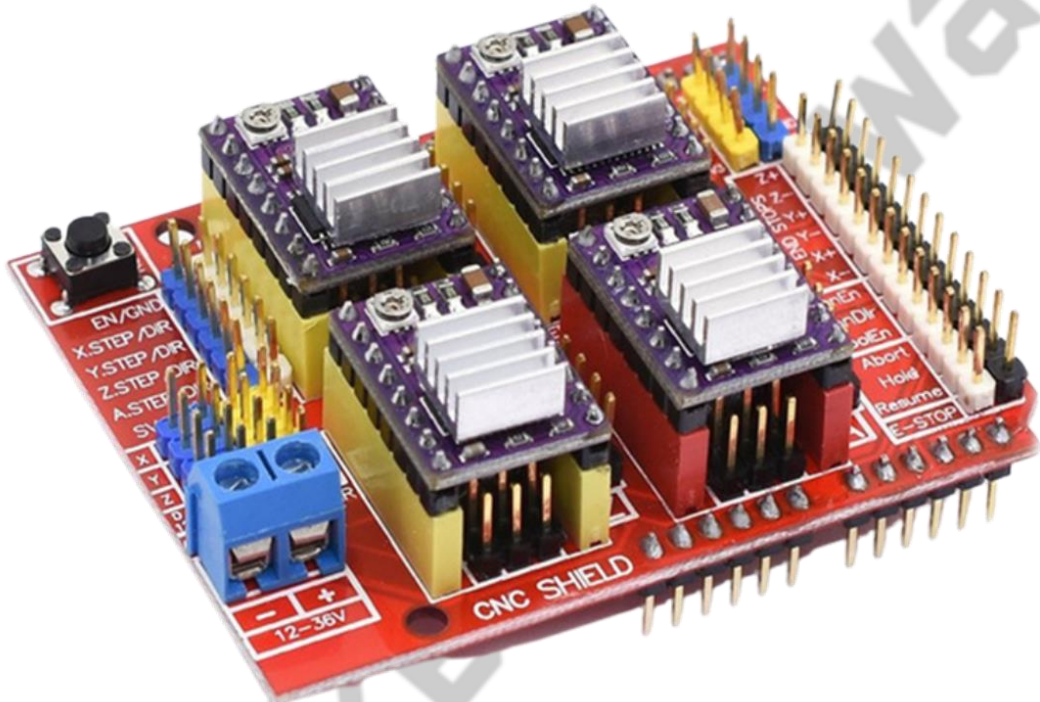

Maker Store CNC Shield Guide



V1.1 12 2022

© Maker Group Global LLC 2022

Maker Store Australia:

<https://www.makerstore.com.au/>

Maker Store UK:

<https://makerstore.co.uk/>

Maker Store USA:

<https://makerstore.cc/>

Safety Statement

The author of this document is not liable or responsible for any accidents, injuries, equipment damage, property damage, loss of money or loss of time resulting from improper use of electrical or mechanical or software products.

Assembling electrical CNC machine components like power supplies, motors, drivers or other electrical components involves dealing with high voltage AC (alternating current) or DC (direct current) which can be extremely dangerous and needs high attention to detail, experience, knowledge of software, electricity and electro-mechanics or mechanics.

BEFORE MAKING ANY CONNECTIONS OR DISCONNECTIONS POWER MUST BE REMOVED FROM THE DEVICE AND THE CONTROLLER. FAILURE TO DO SO WILL VOID ANY AND ALL WARRANTIES.

Introduction

The [CNC Shield](#) was designed by Protoneer.co.nz to take advantage of the demand for a low-cost controller solution for DIY [CNC machines](#). It was designed to be 100% compatible with Grbl, the Opensource G-Code interpreter, and fit onto the popular [Arduino Uno](#). The [CNC Shield](#) can be used to control a number of different types of [CNC machines](#), including CNC milling machines, [laser](#) engraving/cutting [machines](#), [drawing](#) machines, 3D printers or any project that needs precision control of [stepper motors](#). It uses Pololu and compatible stepper drivers, either the [A4988](#) or the higher current [DRV8825](#).

There are 3 main components needed to get the CNC Shield up and running, 1) [CNC Shield](#); 2) [Stepper Drivers](#), and; 3) [Arduino UNO](#). Each of these will be mentioned below.

Version 3.0 of the [CNC Shield](#) is used throughout this guide.

The [CNC Shield](#) is licensed under a Creative Commons Attribution-ShareAlike 3.0 Unported License.

Please note: this document is a guide and not a manual. The [CNC Shield](#) and Grbl are Opensource and under constant development and modification. As a result, **this document provides guidance** but is by no mean comprehensive nor authoritative. It is essential that all users **do their own research** and find solutions that suit their application and requirements.

Features

- **Arduino UNO Compatible** (<https://www.makerstore.com.au/product/elec-unoat16u2/>)
 - 14 digital input/output pins – 6 pins can be used as PWM outputs
 - 6 analog inputs
 - 16 MHz crystal oscillator
 - Operates at 5V
 - Recommended input voltage range: 7V to 12V
 - Flash Memory: 32 KB (0.5KB used by bootloader)
 - SRAM: 2KB
 - EEPROM: 1KB
- **CNC Shield** (<https://www.makerstore.com.au/product/elec-cnc-shield-v4-pk/>)
 - **Version 3.00**
 - 4-Axis support (X, Y, Z, A-Can duplicate X,Y,Z or do a full 4th axis with custom firmware using pins D12 and D13)
 - 2 x End stops for each axis (6 in total - each axis pair shared by same IO pin)
 - Spindle enable and direction connection
 - Coolant enable connection
 - Uses GRBL as control software

- [Power supply](#): DC 12-36V (only the [DRV8825](#) drivers can handle up to 36V so if using [A4988](#) do not exceed 24V)
- Uses removable stepper drivers ([DRV8825](#) or [A4988](#))
- [Stepper motors](#) can be connected with 4 pin dupont/molex connectors
- Jumpers to set Micro-Stepping
- [DRV8825 Stepper Drivers](https://www.makerstore.com.au/product/elec-drv8825/) (<https://www.makerstore.com.au/product/elec-drv8825/>)
 - Low RDS (ON) outputs
 - Automatic current decay mode detection / selection
 - Internal UVLO
 - Mixed with slow current decay modes
 - Synchronous rectification for low power dissipation
 - Crossover-current protection
 - Thermal shutdown circuitry
 - 3.3 and 5 V compatible logic supply
 - Ground Fault Circuit
 - Load short-circuit protection
 - Six microstepping modes: full, 1/2, 1/4, 1/8, 1/16 and 1/32
- [A4988 Stepper Drivers](https://www.makerstore.com.au/product/elec-a4988/) (<https://www.makerstore.com.au/product/elec-a4988/>)
 - Simple step and direction control interface
 - Five different step resolutions: full, 1/2, 1/4, 1/8 and 1/16
 - Adjustable current control lets you set the maximum current output with a potentiometer, which lets you use voltages above your stepper motor's rated voltage to achieve higher step rates
 - Intelligent chopping control that automatically selects the correct current decay mode (fast decay or slow decay)
 - Over-temperature thermal shutdown, under-voltage lockout, and crossover-current protection
 - Short-to-ground and shorted-load protection

Application

Suitable for a variety of small and medium sized automation equipment and instruments, such as: engraving [machine](#), marking machine, cutting machine, [laser](#) typesetting, plotters, [drawbots](#), CNC [machine tools](#), handling the devices.

Machines: <https://www.makerstore.com.au/product-category/cnc-machining/>

Grbl on the UNO

Before connecting the UNO to the [CNC Shield](#) it is best to load Grbl onto the UNO. For a full description and complete details of Grbl please see the Wiki on the Grbl project pages:

<https://github.com/grbl/grbl/wiki>

There are many conversations about which version of Grbl to use with a v3.0 [CNC Shield](#). Protoneer say that only Grbl v0.8 is compatible, but later version can be used with slight modification to the config.h file. For more details about the difference between v0.8 and v0.9 see:

<https://github.com/grbl/grbl/wiki/Connecting-Grbl>

To use v0.9 and higher just comment out the “#define VARIABLE_SPINDLE” line in config.h. For example, in v0.9 this is on line 247:

```
243 // Enables variable spindle output voltage for different RPM values. On the Arduino Uno, the spindle
244 // enable pin will output 5V for maximum RPM with 256 intermediate levels and 0V when disabled.
245 // NOTE: IMPORTANT for Arduino Unos! When enabled, the Z-limit pin D11 and spindle enable pin D12
switch!
246 // The hardware PWM output on pin D11 is required for variable spindle output voltages.
247 #define VARIABLE_SPINDLE // Default enabled. Comment to disable.
```

Change line 247 to:

```
247 // #define VARIABLE_SPINDLE // Default enabled. Comment to disable.
```

For v1.1 change line 339 to:

```
339 // #define VARIABLE_SPINDLE // Default enabled. Comment to disable.
```

So given the above, choose the version of Grbl that suits your application and build and download as per the instructions in the Grbl Wiki page.

There are many settings that can be defined prior to loading Grbl onto the UNO. For more information on what each of the settings mean see the Wiki page:

<https://github.com/grbl/grbl/wiki/Configuring-Grbl-v0.9>

<https://github.com/gnea/grbl/wiki/Grbl-v1.1-Configuration>

Loading Grbl on the UNO

The best and easiest way to load Grbl onto the UNO is to use the Arduino IDE. This can be downloaded from:

<https://www.arduino.cc/en/Main/Software>

Install and follow the instruction as detailed on the Arduino website.

To load Grbl onto the UNO:

1. Open the sketch (from the Arduino IDE menu File/Examples/grbl/grblUpload)
2. In the IDE make sure you have all the settings correctly set for the type of board, port and etc.
3. Click the “Upload” button.
4. The IDE will report “Done Uploading” when it is finished uploading:

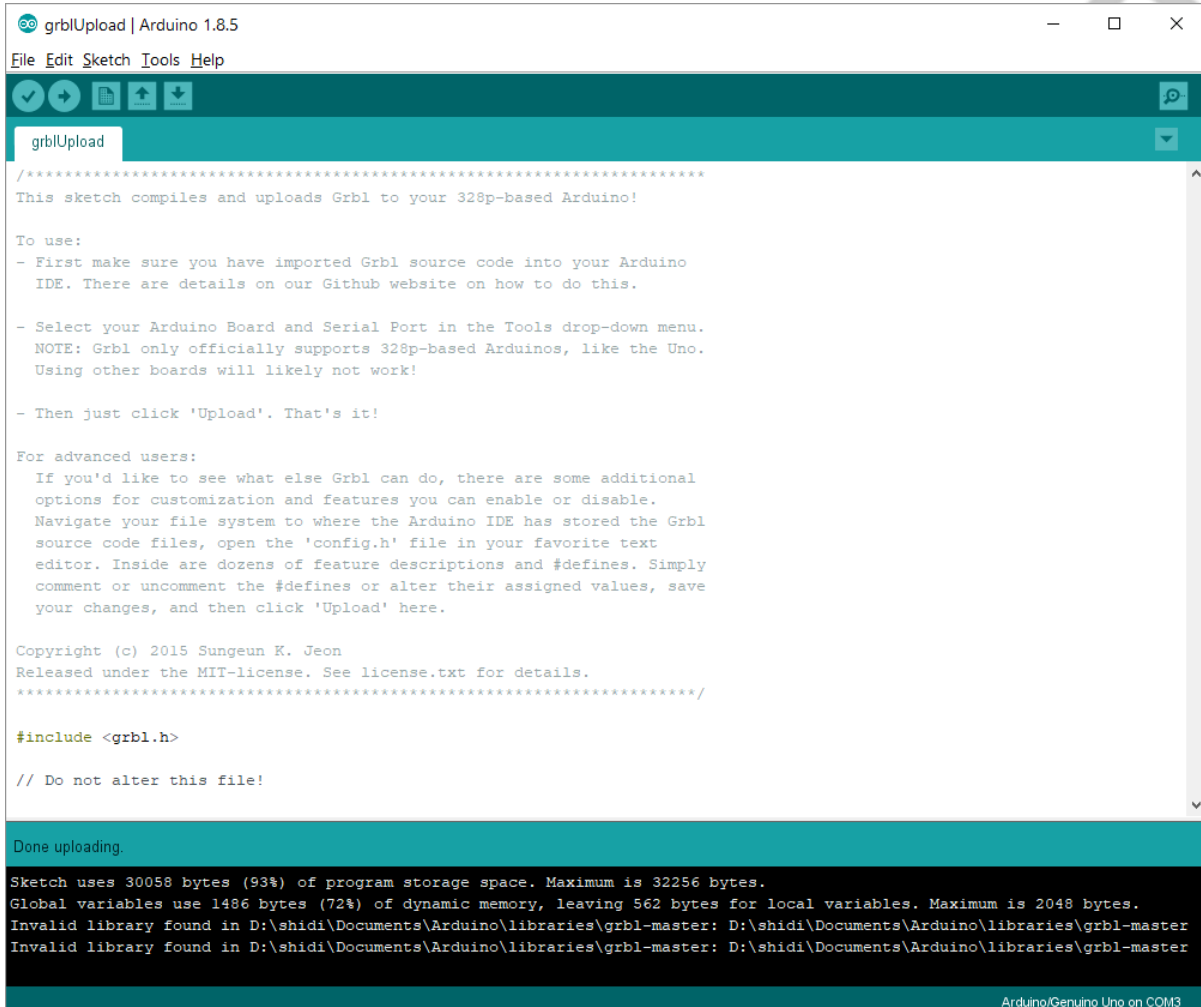

```
grblUpload | Arduino 1.8.5
File Edit Sketch Tools Help
grblUpload
/*****
This sketch compiles and uploads Grbl to your 328p-based Arduino!

To use:
- First make sure you have imported Grbl source code into your Arduino
  IDE. There are details on our Github website on how to do this.

- Select your Arduino Board and Serial Port in the Tools drop-down menu.
  NOTE: Grbl only officially supports 328p-based Arduinos, like the Uno.
  Using other boards will likely not work!

- Then just click 'Upload'. That's it!

For advanced users:
If you'd like to see what else Grbl can do, there are some additional
options for customization and features you can enable or disable.
Navigate your file system to where the Arduino IDE has stored the Grbl
source code files, open the 'config.h' file in your favorite text
editor. Inside are dozens of feature descriptions and #defines. Simply
comment or uncomment the #defines or alter their assigned values, save
your changes, and then click 'Upload' here.

Copyright (c) 2015 Sungeun K. Jeon
Released under the MIT-license. See license.txt for details.
*****/

#include <grbl.h>

// Do not alter this file!

Done uploading.
Sketch uses 30058 bytes (93%) of program storage space. Maximum is 32256 bytes.
Global variables use 1486 bytes (72%) of dynamic memory, leaving 562 bytes for local variables. Maximum is 2048 bytes.
Invalid library found in D:\shidi\Documents\Arduino\libraries\grbl-master: D:\shidi\Documents\Arduino\libraries\grbl-master
Invalid library found in D:\shidi\Documents\Arduino\libraries\grbl-master: D:\shidi\Documents\Arduino\libraries\grbl-master
Arduino/Genuino Uno on COM3
```

5. If you get errors, then please read the Arduino IDE help and/or the Grbl Wiki.

Confirm Grbl on the UNO

1. Open the IDE serial monitor (Tools/Serial Monitor)
2. If Grbl is loaded correctly then it will report the version in the Monitor window:

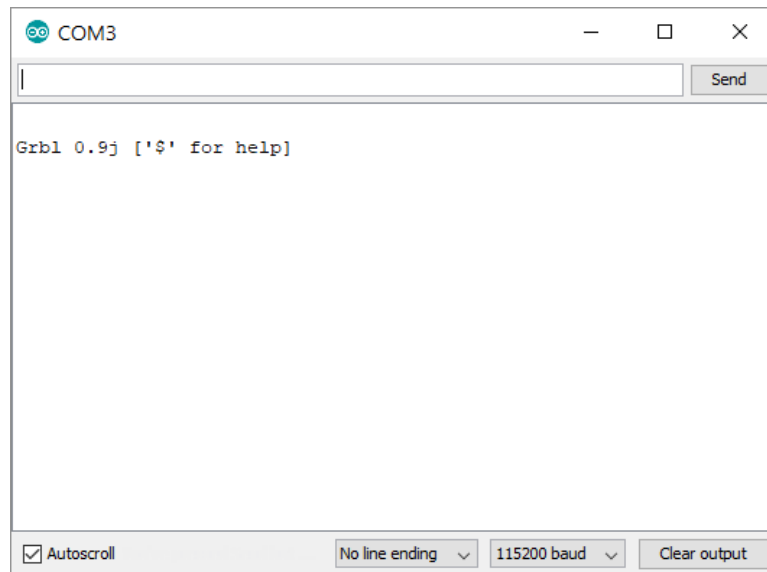

Wiring and Connections Guide

Safety and Handling Requirements

Before wiring it is essential to note a couple of safety issues and handling requirements.

While the voltages on and around the [CNC Shield](#) are low (5V for the Arduino and up to 36V for the [CNC Shield](#) and steppers) it is still possible to hurt both yourself and the components if handled incorrectly or without care.

The following points are critical and cannot be emphasized strongly enough. **Read carefully:**

1. **NEVER** connect or disconnect any stepper motor to the [CNC Shield](#) while power is on or connected.
2. **ALWAYS** disconnect the power before connecting or disconnecting the [stepper motors](#).
3. When installing the driver make sure to **correctly orientate** the driver so the **enable pin (EN)** matches the EN pin on the [CNC Shield](#) (top left). Note that the small potentiometer is on the bottom of the [A4988](#) while it is on the top of the [DRV8825](#) – so take care not to confuse the two drivers.

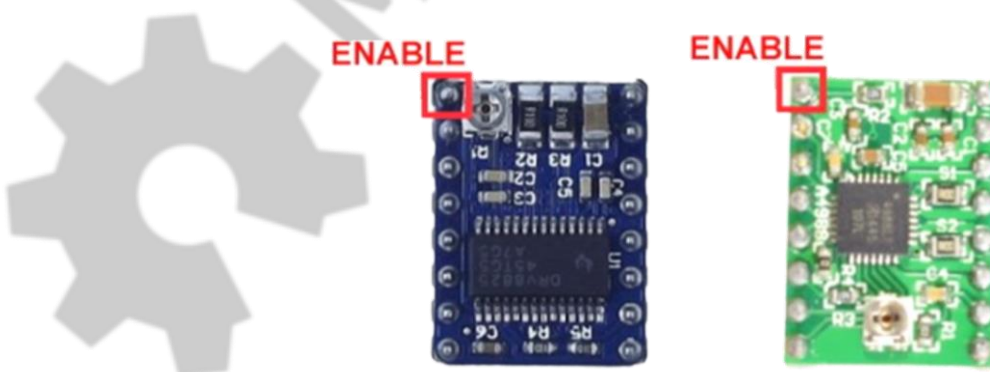

4. **ALWAYS** connect a stepper motor to the [CNC Shield](#) when testing or using the [CNC Shield](#) and driver. This is very important because the stepper drivers are designed to ramp up the current until it reaches

the current needed to run. Without a stepper motor connected there will be nothing to consume the current and you can end up damaging the stepper driver if it over-heats in the process.

- When affixing a heatsink to the drivers it is **critical not to short out any of the pins**. Place the heatsink in the middle. Failure to correctly place the heatsink can lead to the driver shorting out and failing. This a common cause of driver failure and is a very common handling error.

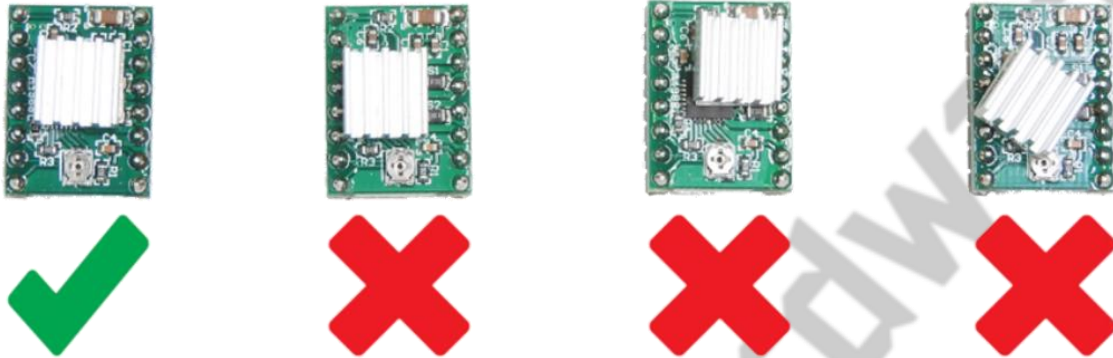

Component Assembly

Below is a general outline process for connection of the various components:

- Taking normal static electricity precautions, insert the [CNC Shield](#) into the [Arduino Uno](#) making sure the correct pins of the [CNC Shield](#) are inserted into the correct UNO headers.
- Decide on the micro stepper setting for your application and place the jumpers as required

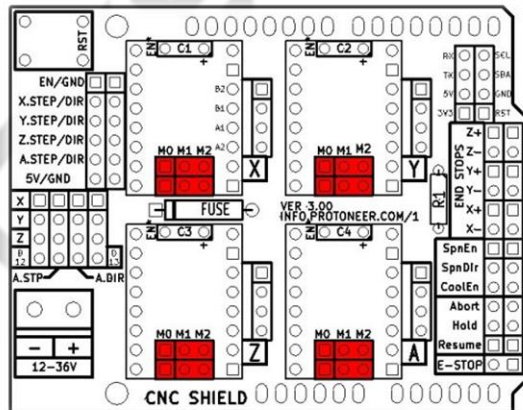

In the tables below High indicates that a Jumper is insert and Low indicates that no jumper is inserted.

[A4988](#) Stepper Driver configuration:

M0	M1	M2	Microstep Resolution
Low	Low	Low	Full step
High	Low	Low	Half step
Low	High	Low	Quarter step
High	High	Low	Eighth step
High	High	High	Sixteenth step

[DRV8825](#) Stepper Driver configuration:

M0	M1	M2	Microstep Resolution
Low	Low	Low	Full step
High	Low	Low	Half step
Low	High	Low	1/4 step
High	High	Low	1/8 step
Low	Low	High	1/16 step
High	Low	High	1/32 step
Low	High	High	1/32 step
High	High	High	1/32 step

3. Insert the stepper drivers into the [CNC Shield](#) paying special attention to match the enable pin (EN) to the enable socket (EN).
4. Connect the [stepper motors](https://www.makerstore.com.au/product-category/electronics/motors-servos/stepper-motors/) (<https://www.makerstore.com.au/product-category/electronics/motors-servos/stepper-motors/>) to the header pins. Take care to check your [stepper motor](#) to make sure the correct wiring sequence. Different [stepper motors](#) have different colour wires, so use the stepper's Technical Specifications sheet to determine the sequence.

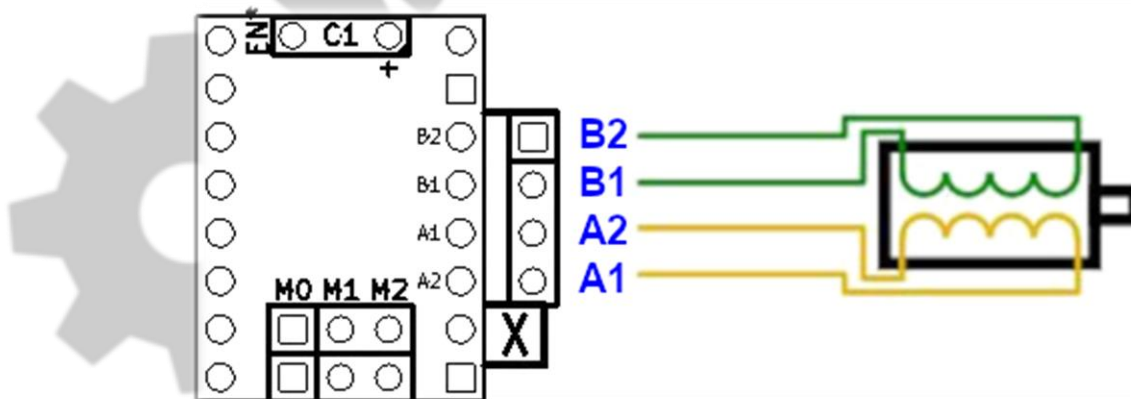

5. Referring to the details on the Protoneer website, set jumpers for slave axis and connect additional [limit](#)/home switches and probes as per your application requirements, see:

<https://blog.protoneer.co.nz/arduino-cnc-shield-v3-00-assembly-guide/>

Testing

Protoneer has published what they call a “Pre-Flight Checklist”. This is a great resource for testing the [CNC Shield](#).

See:

<https://blog.protoneer.co.nz/arduino-cnc-shield-v3-00-assembly-guide/>

Configuring Grbl

There are many Wikis, blogs and posts about how to configure Grbl, see the links section below for some. For Grbl v0.9 see:

<https://github.com/grbl/grbl/wiki/Configuring-Grbl-v0.9>

Connect to the UNO using a serial console program like Putty or a Grbl GUI (see links below for some examples) and enter “\$\$” to see a list of settings:

```
$0=10 (step pulse, usec)
$1=25 (step idle delay, msec)
$2=0 (step port invert mask:00000000)
$3=6 (dir port invert mask:00000110)
$4=0 (step enable invert, bool)
$5=0 (limit pins invert, bool)
$6=0 (probe pin invert, bool)
$10=3 (status report mask:00000011)
$11=0.020 (junction deviation, mm)
$12=0.002 (arc tolerance, mm)
$13=0 (report inches, bool)
$20=0 (soft limits, bool)
$21=0 (hard limits, bool)
$22=0 (homing cycle, bool)
$23=1 (homing dir invert mask:00000001)
$24=50.000 (homing feed, mm/min)
$25=635.000 (homing seek, mm/min)
$26=250 (homing debounce, msec)
$27=1.000 (homing pull-off, mm)
$100=314.961 (x, step/mm)
$101=314.961 (y, step/mm)
$102=314.961 (z, step/mm)
$110=635.000 (x max rate, mm/min)
$111=635.000 (y max rate, mm/min)
$112=635.000 (z max rate, mm/min)
$120=50.000 (x accel, mm/sec^2)
$121=50.000 (y accel, mm/sec^2)
$122=50.000 (z accel, mm/sec^2)
$130=225.000 (x max travel, mm)
$131=125.000 (y max travel, mm)
$132=170.000 (z max travel, mm)
```

It is essential to modify these settings to suit your application, machine and requirements.

Images

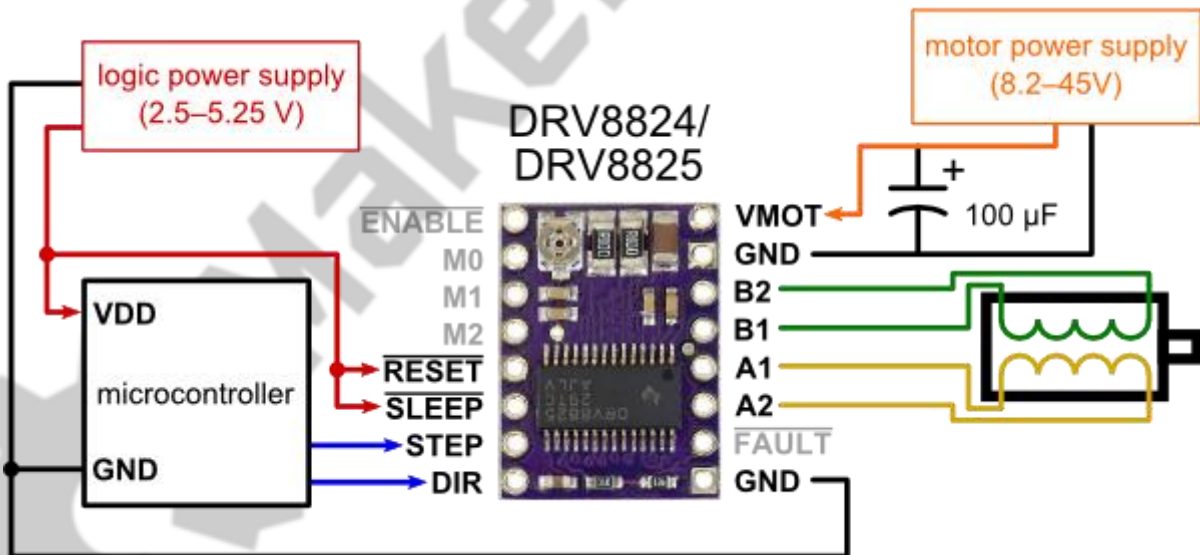
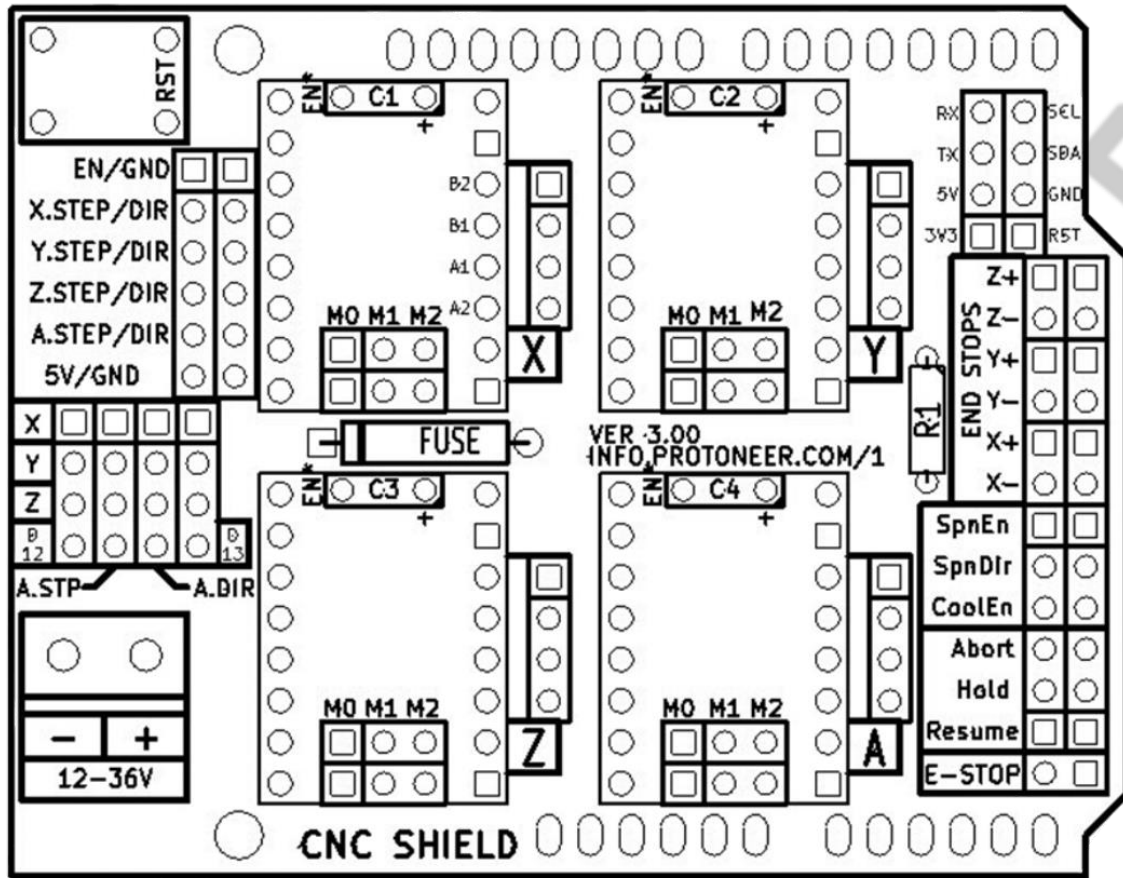

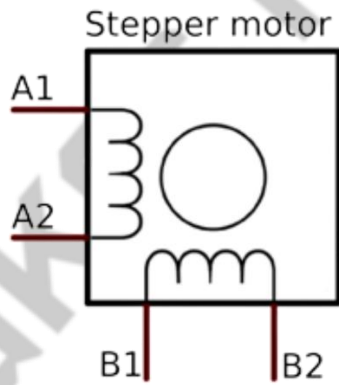
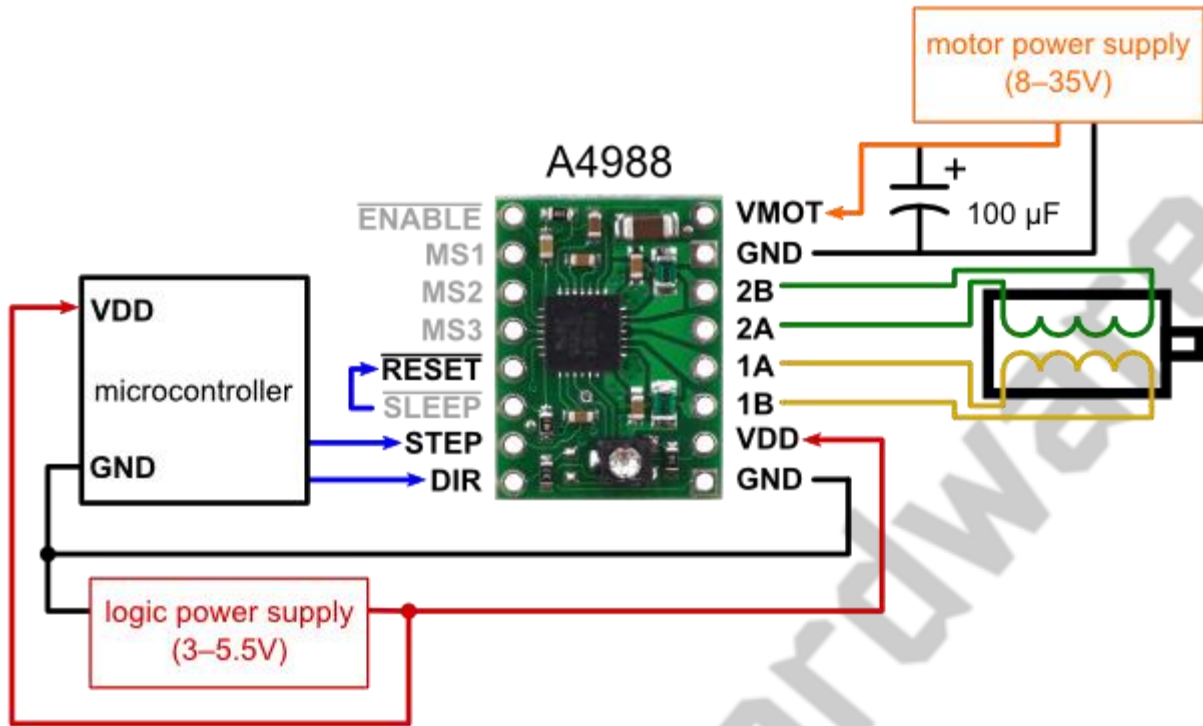

Links and Credits

Designer of the CNC Shield:	https://blog.protoneer.co.nz/arduino-cnc-shield/
Grbl to v0.9:	https://github.com/grbl/grbl/wiki
Grbl from v1.1:	https://github.com/gnea/grbl/wiki
Grbl GUIs:	https://github.com/gnea/grbl/wiki/Using-Grbl
Driver Details:	https://www.pololu.com/category/120/stepper-motor-drivers
Wikipedia Arduino entry:	https://en.wikipedia.org/wiki/Arduino
Arduino IDE:	https://www.arduino.cc/en/Main/Software
PuTTY serial console:	https://www.putty.org/
CNC Shields:	https://www.makerstore.com.au/product/elec-cnc-shield-v4-pk/
Arduino UNO:	https://www.makerstore.com.au/product/elec-unoat16u2/
CNC Machines:	https://www.makerstore.com.au/product-category/cnc-machining/
Stepper Drivers:	https://www.makerstore.com.au/product-tag/stepper-driver/
Stepper Motors:	https://www.makerstore.com.au/product-category/electronics/motors-servos/stepper-motors/