

## PNP SILICON TRANSISTORS

- SGS-THOMSON PREFERRED SALESTYPES
- PNP TRANSISTOR

### DESCRIPTION

The BD136, BD138 and BD140 are silicon epitaxial planar PNP transistors in Jedec SOT-32 plastic package, designed for audio amplifiers and drivers utilizing complementary or quasi complementary circuits.

The complementary NPN types are the BD135, BD137 and BD139.

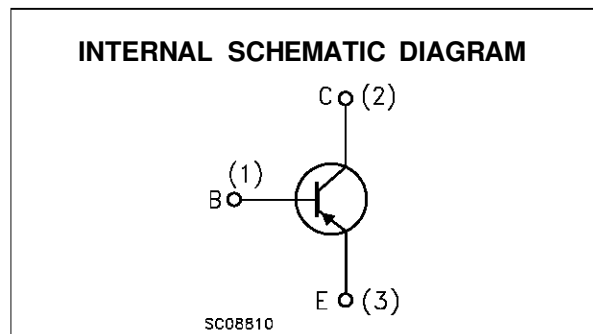
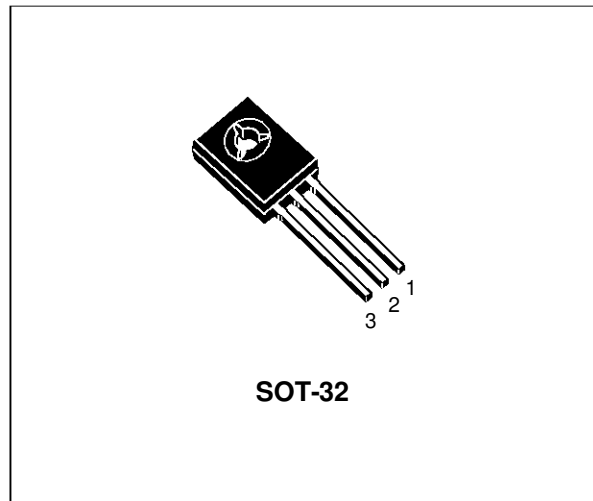

### ABSOLUTE MAXIMUM RATINGS

Symbol	Parameter	Value			Unit
		BD136	BD138	BD140	
$V_{CBO}$	Collector-Base Voltage ( $I_E = 0$ )	-45	-60	-80	V
$V_{CEO}$	Collector-Emitter Voltage ( $I_B = 0$ )	-45	-60	-80	V
$V_{EBO}$	Emitter-Base Voltage ( $I_C = 0$ )	-5			V
$I_C$	Collector Current	-1.5			A
$I_{CM}$	Collector Peak Current	-3			A
$I_B$	Base Current	-0.5			A
$P_{tot}$	Total Dissipation at $T_c \leq 25^\circ\text{C}$	12.5			W
$P_{tot}$	Total Dissipation at $T_{amb} \leq 25^\circ\text{C}$	1.25			W
$T_{stg}$	Storage Temperature	-65 to 150			$^\circ\text{C}$
$T_j$	Max. Operating Junction Temperature	150			$^\circ\text{C}$

# BD136/BD138/BD140

## THERMAL DATA

$R_{thj-case}$	Thermal Resistance Junction-case	Max	10	$^{\circ}C/W$
----------------	----------------------------------	-----	----	---------------

## ELECTRICAL CHARACTERISTICS ( $T_{case} = 25^{\circ}C$ unless otherwise specified)

Symbol	Parameter	Test Conditions	Min.	Typ.	Max.	Unit
$I_{CBO}$	Collector Cut-off Current ( $I_E = 0$ )	$V_{CB} = -30 V$ $V_{CB} = -30 V \quad T_C = 125^{\circ}C$			-0.1 -10	$\mu A$ $\mu A$
$I_{EBO}$	Emitter Cut-off Current ( $I_C = 0$ )	$V_{EB} = -5 V$			-10	$\mu A$
$V_{CEO(sus)*}$	Collector-Emitter Sustaining Voltage	$I_C = -30 mA$ for <b>BD136</b> for <b>BD138</b> for <b>BD140</b>	-45 -60 -80			V V V
$V_{CE(sat)*}$	Collector-Emitter Saturation Voltage	$I_C = -0.5 A \quad I_B = -0.05 A$			-0.5	V
$V_{BE*}$	Base-Emitter Voltage	$I_C = -0.5 A \quad V_{CE} = -2 V$			-1	V
$h_{FE*}$	DC Current Gain	$I_C = -5 mA \quad V_{CE} = -2 V$ $I_C = -0.5 A \quad V_{CE} = -2 V$ $I_C = -150 mA \quad V_{CE} = -2 V$	25 25 40		250	
$h_{FE}$	$h_{FE}$ Groups	$I_C = -150 mA \quad V_{CE} = -2 V$ for BD140 group 10	63		160	

\* Pulsed: Pulse duration = 300  $\mu s$ , duty cycle 1.5 %

## Safe Operating Areas

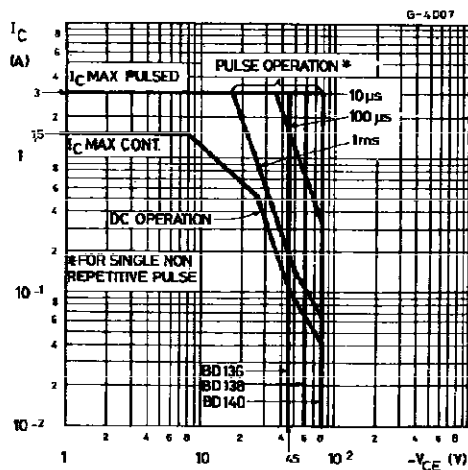

## SOT-32 (TO-126) MECHANICAL DATA

DIM.	mm			inch		
	MIN.	TYP.	MAX.	MIN.	TYP.	MAX.
A	7.4		7.8	0.291		0.307
B	10.5		10.8	0.413		0.445
b	0.7		0.9	0.028		0.035
b1	0.49		0.75	0.019		0.030
C	2.4		2.7	0.040		0.106
c1	1.0		1.3	0.039		0.050
D	15.4		16.0	0.606		0.629
e		2.2			0.087	
e3	4.15		4.65	0.163		0.183
F		3.8			0.150	
G	3		3.2	0.118		0.126
H			2.54			0.100
H2		2.15			0.084	

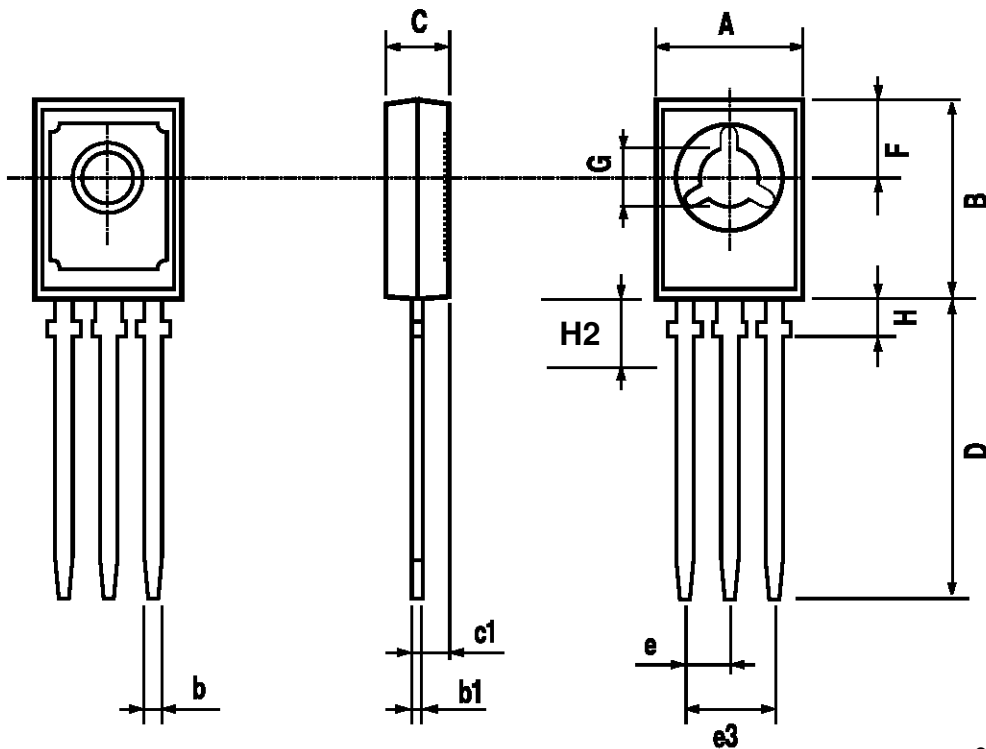

0016114

Information furnished is believed to be accurate and reliable. However, SGS-THOMSON Microelectronics assumes no responsibility for the consequences of use of such information nor for any infringement of patents or other rights of third parties which may result from its use. No license is granted by implication or otherwise under any patent or patent rights of SGS-THOMSON Microelectronics. Specifications mentioned in this publication are subject to change without notice. This publication supersedes and replaces all information previously supplied. SGS-THOMSON Microelectronics products are not authorized for use as critical components in life support devices or systems without express written approval of SGS-THOMSON Microelectronics.

© 1997 SGS-THOMSON Microelectronics - Printed in Italy - All Rights Reserved

SGS-THOMSON Microelectronics GROUP OF COMPANIES  
Australia - Brazil - Canada - China - France - Germany - Hong Kong - Italy - Japan - Korea - Malaysia - Malta - Morocco - The Netherlands -  
Singapore - Spain - Sweden - Switzerland - Taiwan - Thailand - United Kingdom - U.S.A  
...